

TECHNICAL SPECIFICATIONS – PIVOT & HINGE DOORS

300C - Continuous Hinge - 3/16" Glass

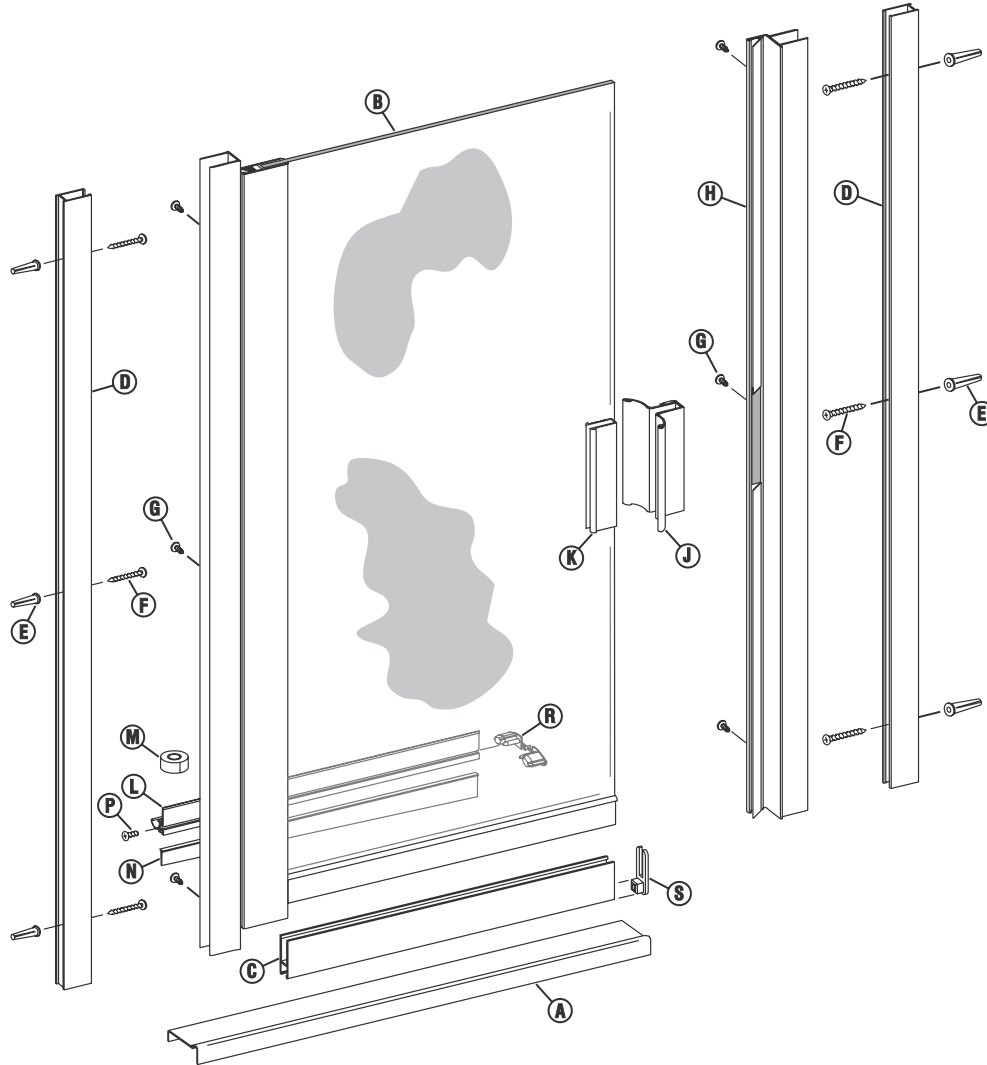

- A.** 1 SC-915 Shower Curb
- B.** 1 Glazed Door Panel Assembly
- C.** 1 SC-558 Bottom Rail
- D.** 2 SC-508 Wall Jambs
- E.** 6 Plastic Wall Anchors
- F.** 6 #8 x 1 1/2 Truss Head Screws

- G.** 6 #6 x 3/8 Pan Head Tex Screws
- H.** 1 SC-552 Strike Jamb w/Magnet
- J.** 1 Pull Handle
- K.** 1 Handle Vinyl
- L.** 1 SC-589 Drip Rail
- M.** 1 Roll of Double-Stick Tape

- N.** 1 Tapered Drip Vinyl
- P.** 1 #6 x 3/8 Pan Head Screw
- R.** 1 Set Drip Rail Plugs
- S.** 1 Rail End Cap

Calculations

Maximum allowable width of unit = 37 (@ 72 tall)
 Maximum allowable height of unit = 84 (@ 30 wide)

Glass Size

Width = Unit width - 3 5/8
 Height = Unit ht. - 2 1/16

Adjustment for Wall Conditions

+ 3/8" on Both Sides
 - 0"

Metal Cuts

SC-508 wall jamb = Unit ht. - 7/16
 SC-552 strike jamb = Unit ht. - 7/16
 SC-558 bottom rail = Unit width - 4 1/2
 SC-589 drip rail = Bottom rail + 1 1/4
 SC-649 hinge jamb = Unit ht. - 7/16
 SC-651 hinge rail = Unit ht. - 1 9/16
 SC-915 curb = Unit width