

TECHNICAL SPECIFICATIONS – SLIDING ENCLOSURES

340 / 350 - Semi-Frameless Slider - 3/16" Glass

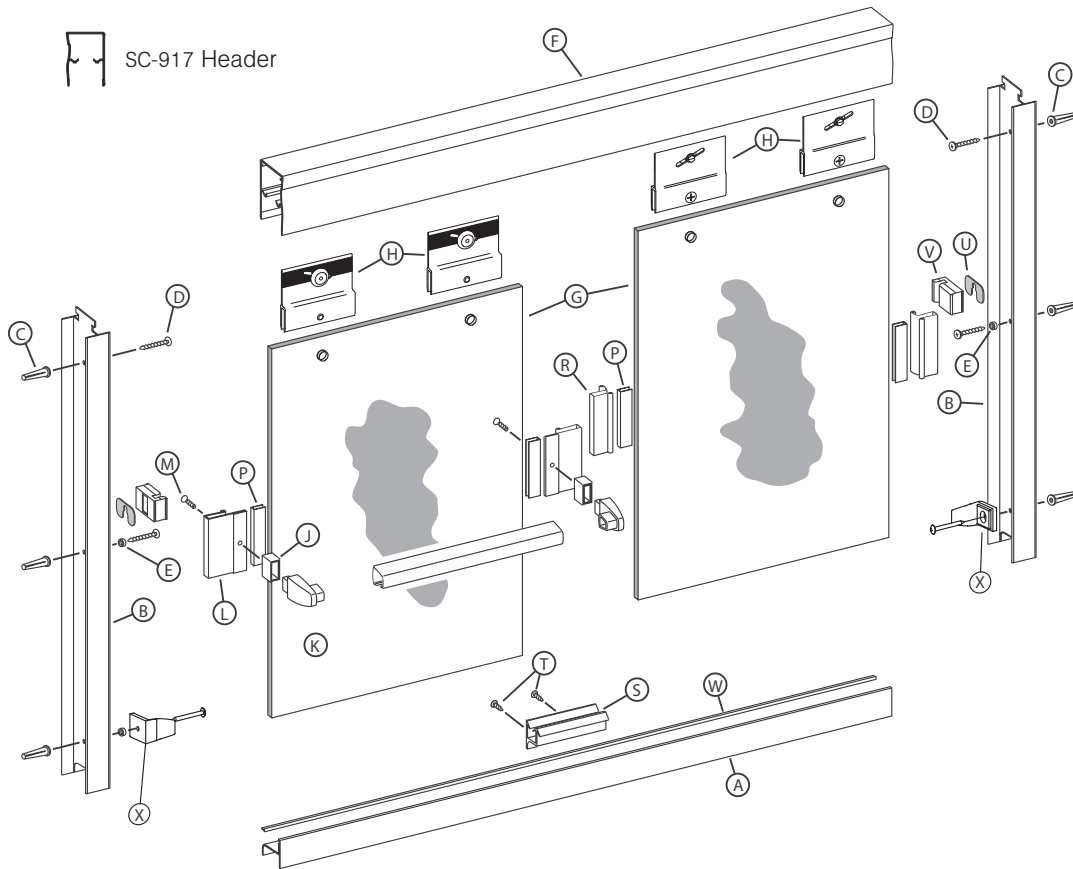

- A.** 1 SC-556 Tub Track with Vinyl
- B.** 2 SC-896 Wall Jamba
- C.** 6 Plastic Wall Anchors
- D.** 6 #8 x 1 1/2 Truss Head Screws
- E.** 2 Nylon Spacers
- F.** 1 SC-917 Header
- G.** 2 Glass Lites

- H.** 4 Hanger Brackets (Pre-assembled)
- J.** 2 Trim Rings
- K.** 2 Acrylic Towel Bar Brackets
- L.** 2 Towel Bar Bases
- M.** 2 #10-24 x 1/2 Flat Head Screws
- N.** 1 SC-805 Towel Bar
- P.** 4 Vinyl Shims

- R.** 2 Pull Handles
- S.** 1 PVC Bottom Guide
- T.** 2 #6 x 3/8 Pan Head Screw
- U.** 2 Stainless Bumper Inserts
- V.** 2 Vinyl Jamb Bumpers
- W.** 1 Vinyl Silencer
- X.** Bottom Bumper (Optional)

Calculations

Maximum allowable width of unit = 72
 Maximum allowable height of unit = 72

Adjustment for Wall Conditions

± 3/16" on Both Sides

Glass Size

Width = (Unit Width ÷ 2)
 Height = Unit Ht. - 3

Metal Cuts

SC-556 tub track = Unit width - 1/16
 SC-805 towel bar = Glass width - 2 7/8
 SC-896 wall jamb = Unit ht. - 1 1/2
 SC-917 Header = Unit width - 1/16