

Tel: 800-643-1514

À

[www.alumaxshowerdoor.com](http://www.alumaxshowerdoor.com)

# 338 SERIES FRAMELESS PIVOT SHOWER DOOR

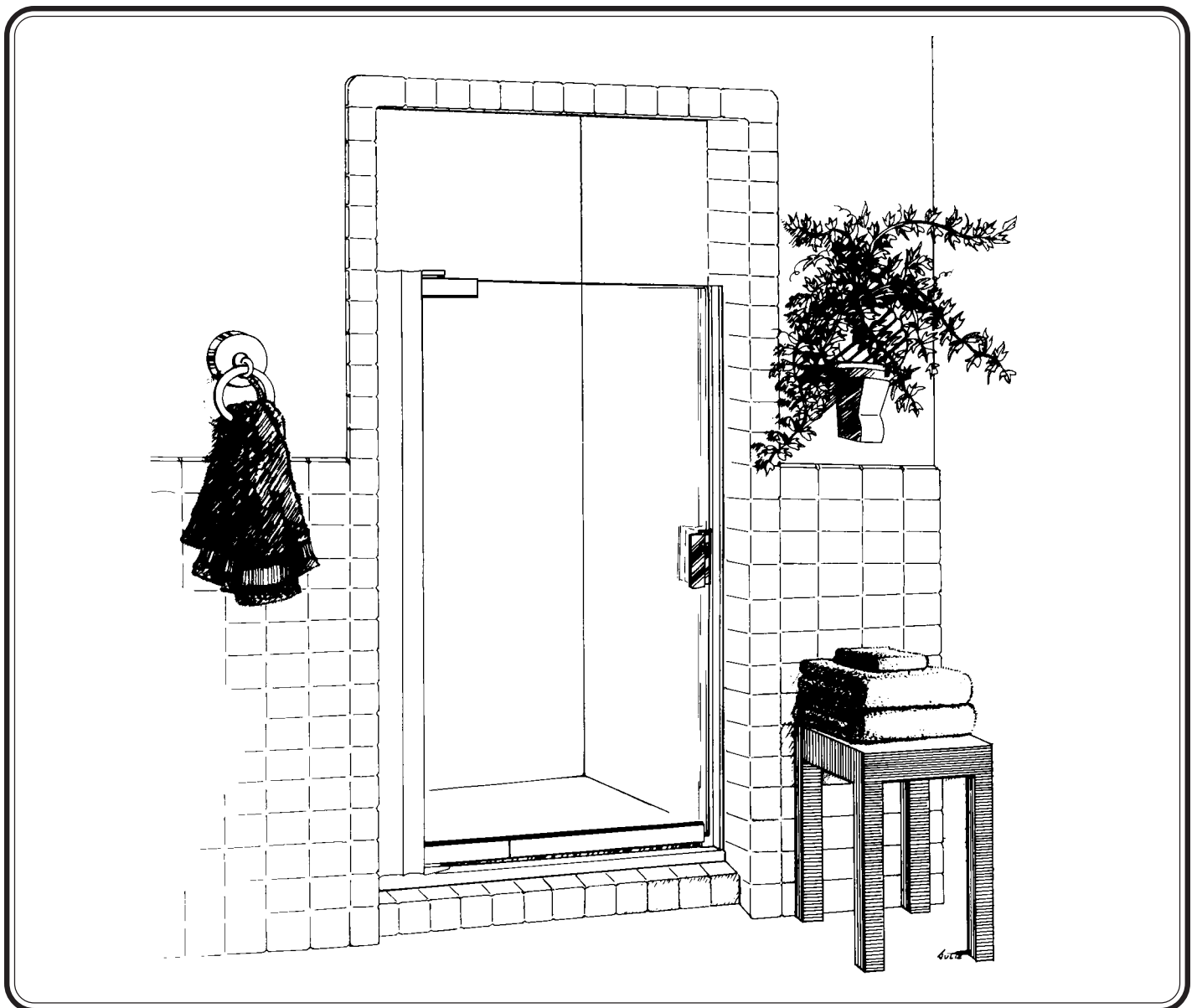

## **!WARNINGS!**

### INSTALLATION WARNINGS

- a) Alumax Bath Enclosures by Sapa are intended to be installed by an experienced installer. If you need assistance with locating an experienced installer, contact us at 1.800.643.1514 or go to our website [www.alumaxshowerdoor.com](http://www.alumaxshowerdoor.com) to access our "dealer locator". If a dealer is not listed in your area, call or send us an e-mail and we will find one for you.
- b) The enclosure must be properly installed per our published installation instructions. If NOT, the unit will not operate as designed which will cause hardware failure, glass breakage, leaking, other unidentified issues, and may cause nullification of warranty.
- c) Unpack your unit carefully and inspect for freight damage. Lay out and identify all parts using the instruction sheets as a reference. Before discarding the carton, check for small hardware bags that tend to fall into the bottom of the box. If any parts are damaged or missing, refer to the descriptions noted in the instructions when contacting your dealer for replacements.
- d) Before beginning installation, check the tub rim for level and both walls for plumb. If either is off more than ¼" to 3/8", you should use a tapered filler which can be used to level the tub track or plumb the wall jambs.
- e) Wear safety glasses when drilling or cutting to avoid injury to the eyes.
- f) When drilling holes in ceramic tile or marble, use a center punch and hammer to carefully break the surface glaze so the drill can start without skidding. A skidding drill can cause damage to the surface and can be dangerous (risk of personal injury).
- g) Use caution and proper technique whenever using tools to avoid damage to property and/or personal injury.

### GENERAL USAGE AND HANDLING WARNINGS

- a) Shower doors are not leak-proof. They are designed to direct water to the interior of the tub or shower under normal conditions. Excessive water pressure or directing the shower head directly at the door can result in leaks.
- b) Do not hang on towel bars or handles or use them to support your weight getting in and out of the bathtub or shower. Towel bars and handles are not intended to be used as grab bars for assistance getting in and out of the shower or bathtub. They are not intended to support a person's weight and could break.
- c) Do not use excessive force when opening and closing the enclosure. Excessive force can lead to glass breakage or other damage to the enclosure. Make sure wall jamb bumpers are securely fastened in place per the installation instructions.

### GLASS USAGE AND HANDLING WARNINGS

- a) **TEMPERED GLASS CANNOT BE CUT.** Attempting to cut tempered glass will result in the glass breaking or shattering.
- b) **USE CAUTION WHEN HANDLING GLASS PANELS.** Safety tempered glass is very resistant to breakage, but it can still break if unequal pressure is placed on it during installation (or if cutting of the glass is attempted). In addition, the sharp corners of the panels can damage tile and floor coverings or cause injury.
- c) **PROTECT THE EDGES OF THE GLASS.** Never let the edge of the glass come in direct contact with concrete, tile, marble or other hard surfaces that may nick, or damage the glass edge in any way as this damage may cause a delayed blow. Always check the edge of the glass for nicks, slivers, rough areas, or clam shelling. Do not install the glass if these conditions are present.
- d) Alumax Bath Enclosures by Sapa is not liable for glass breakage of any kind.

### CARE AND CLEANING WARNINGS

- a) The simplest and preferred method of cleaning your unit is by washing it with clean water and drying with a soft cloth.
- b) If soil is still present after drying, a non-abrasive cleanser with a pH of seven to eight may be used. Comet Bathroom Cleaner® has been tested and is recommended by the Bath Enclosure Manufacturers Association (BEMA).
- c) Contact your dealer for more information about glass coatings that will help keep the glass clean.
- d) **DO NOT USE SCOURING PADS, SHARP INSTRUMENTS, BLEACH OR ACID-BASED CLEANSERS TO CLEAN THE UNIT AS THEY MAY DAMAGE THE UNIT.**

### LIMITED WARRANTY

- a) Alumax Bath Enclosures by Sapa provides a LIMITED WARRANTY on material and workmanship only. Primary glass and component suppliers must be included in all warranty claims.
- b) Alumax Bath Enclosures by Sapa is not responsible for glass breakage.
- c) Products must be handled, installed and maintained per our published Warning and Installation instructions or the warranty may be nullified.
- d) The Limited Warranty applies to the original owner only, and is not transferable.
- e) Please visit our website [www.alumaxshowerdoor.com](http://www.alumaxshowerdoor.com) or call us at 1.800.643.1514 to get copies of our published warranty, installation and warranty policies.

# 338 PARTS LIST

- A. 1 Curb
- B. 3 Rolls of Tape (double-stick)
- C. 1 Pivot Jamb Seal Vinyl
- D. 1 Pivot Jamb
- E. 2 Pivot Brackets
- F. 3 #6 x 3/8" Truss Head Screws
- G. 2 #8 x 1/8" Socket Set Screws
- H. 1 Allen Wrench (5/64")

- J. 6 Plastic Wall Anchors
- K. 3 #8 x 2" Truss Head Screws
- L. 1 Glazed Door Panel
- M. 1 Bottom Rail (See Note)
- N. 2 #10 x 7/16" Set Screws
- P. 2 Pivot Blocks
- R. 2 Nylon Pivot Bushings
- S. 1 Strike Jamb (w/Magnet)

- T. 3 #8 x 1 1/2" Flat Head Screws
- U. 1 Door Handle (w/Magnet)
- V. 1 Door Handle Vinyl (4")
- W. 1 Drip Rail
- X. 1 Tapered Drip Vinyl
- Y. 2 Drip Plugs
- AA. 4 Rail End Caps

**NOTE:**

This exploded view is typical for a glazed unit with obscure or Deco glass. A glazed door panel with clear glass will ship with a 1-piece bottom rail already installed.

- Set screws may be pre-installed in pivot blocks.

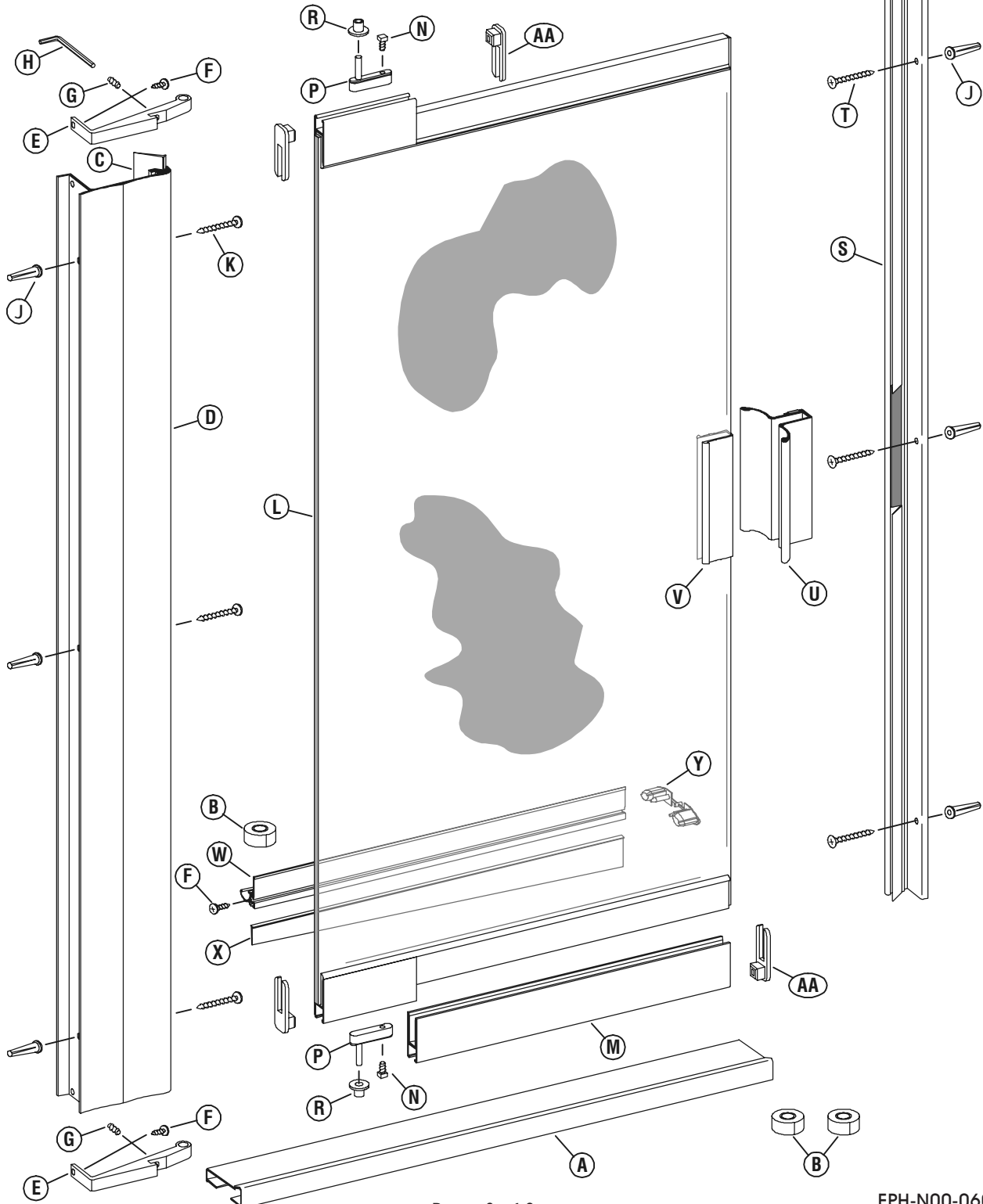

# 1

The ALUMAX 338 Frameless Pivot Shower Door is completely reversible and may be installed pivot-right or pivot-left. Refer to the illustration to determine the correct position for your installation. For maximum waterproofing, the pivot jamb should always be opposite the shower head. These instructions depict a pivot-left installation.

**CAUTION:** For safety, the door must *always* open outward.

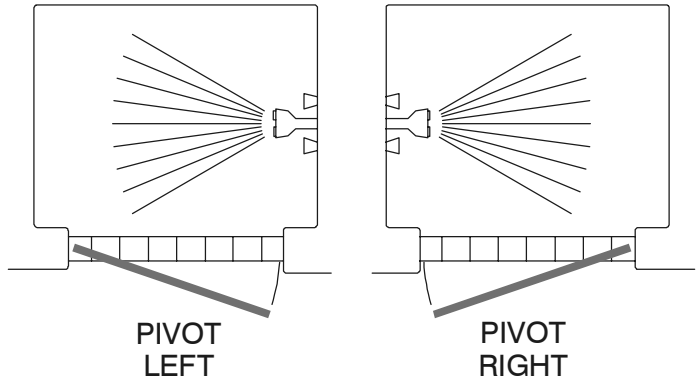

# 2

**NOTE:** The 338 unit may be installed without using the sloped curb [A] provided. Its use is definitely recommended for positive water control on shower sills with little or no slope.

Measure the wall-to-wall opening at the shower sill and cut the curb to the exact length. File the ends of curb as necessary to fit the corner contours of the enclosure. Place the curb on the shower sill with the raised portion to the exterior of the enclosure. Make sure the curb is centered on the sill and lightly mark its position on the sill with a pencil. Remove the curb from the sill.

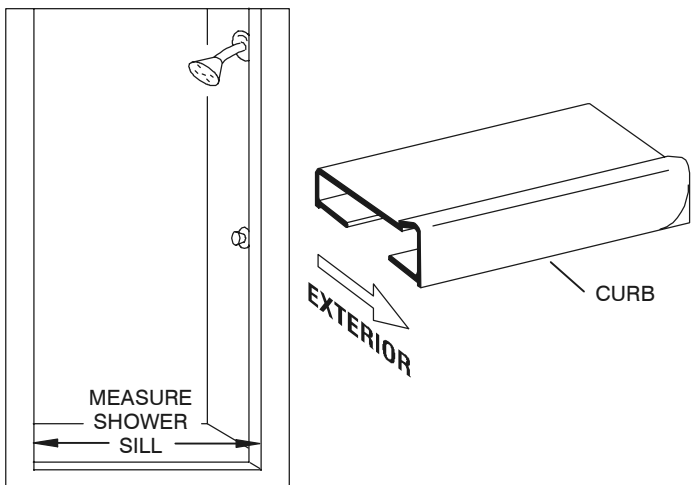

# 3

Unroll the double-stick tape [B] and carefully press the sticky side onto the flat surfaces on the bottom of the curb [A]. Remove the protective covering from the tape and very carefully replace the curb on the shower sill in the exact position marked in Step #2.

**OPTION:** Place a bead of caulk on both flat surfaces on the bottom of the curb. Then replace the curb on the shower sill between the pencil marks and press firmly into place.

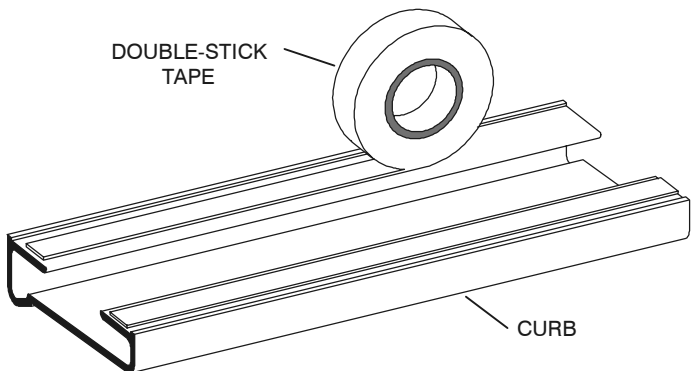

## 4

Cut the clear pivot jamb seal vinyl [C] 3/4" shorter than the pivot jamb [D]. Slide the jamb seal vinyl into the slot in the pivot jamb. Lubricating the vinyl with a small amount of soap or graphite will help installation. Slide one of the pivot brackets [E] into the bottom of the pivot jamb. Lock it in place with a #6 x 3/8" truss head screw [F] and a #8-32 x 1/8" set screw [G] (a 5/64" allen wrench [H] is provided).

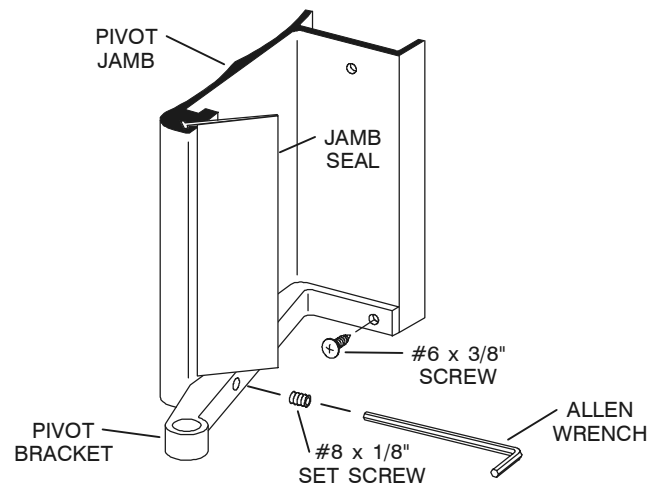

## 5

Place the pivot jamb assembly on the curb [A] with the exterior face lined up with the raised edge of the curb. Use a level to plumb the jamb, then mark the mounting hole locations. Remove the jamb and drill the mounting holes.

For tile or marble walls, drill three 3/16" diameter holes and insert the plastic wall anchors [J]. Attachments to fiberglass or acrylic units can be made in two ways. If a reinforcement is built into the wall of the unit, drill three 1/8" diameter holes to install mounting screws directly into the reinforcement. If walls are not reinforced, drill 3/16" holes and install plastic wall anchors or Molly bolts (Molly bolts not supplied by ALUMAX).

Replace the pivot jamb and attach to the wall with three #8 x 2" truss head screws [K].

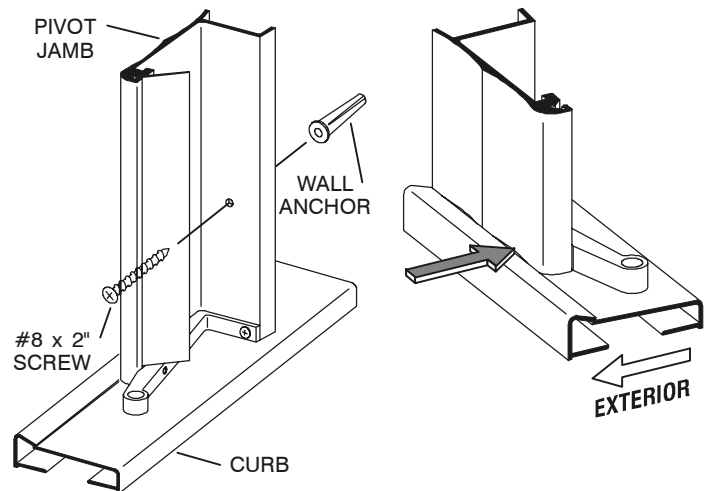

## 6

**NOTE:** Obscure glass doors should be installed with the rough surface of the glass to the exterior of the unit. Deco or etched glass doors should be installed with the patterned surface to the inside.

Glazed doors [L] with obscure or Deco glass will have short rails installed with full width vinyl on both ends. Determine which end will be the bottom. Using a mallet or a hammer and wood block (never a hammer alone), carefully drive the bottom rail [M] over the bottom edge of the glass and vinyl, snug to the factory installed rail. Both rails should be set back 1/8" from the pivot edge of the door and the bottom rail should end 1/8" from the strike edge. Trim the excess vinyl even with the ends of the rails.

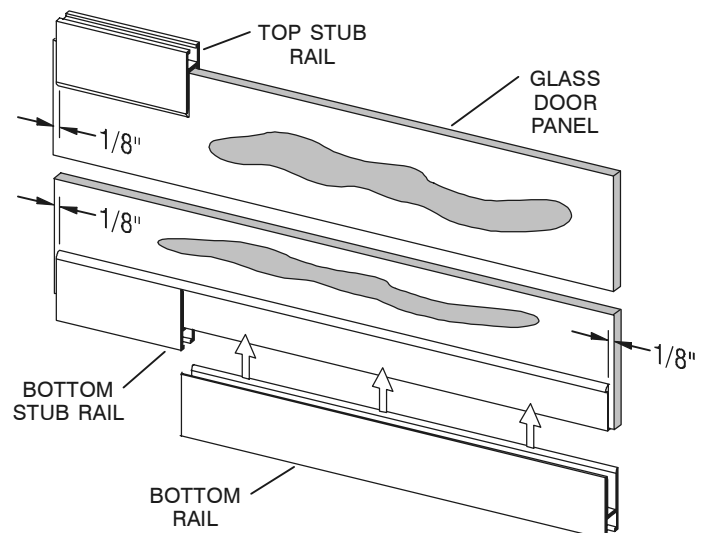

# 7

Thread the two #10-24 x 7/16" square head set screws [N] into the tapped holes in the pivot blocks [P]. Slide the pivot blocks into the top and bottom rails of the glass door panel [L] with the stainless steel pins toward the pivot side of the door (see detail).

Measure the distance from wall to wall directly above the curb (Dim. "A"). Deduct 3 3/4" from this amount and position the pivot pins this exact distance (Dim. "B") from the strike edge of the glass. Tighten the set screws just enough to prevent the pivot blocks from moving (finger tight plus a quarter turn). A 3/16" wrench (not supplied by ALUMAX) will fit the set screw heads.

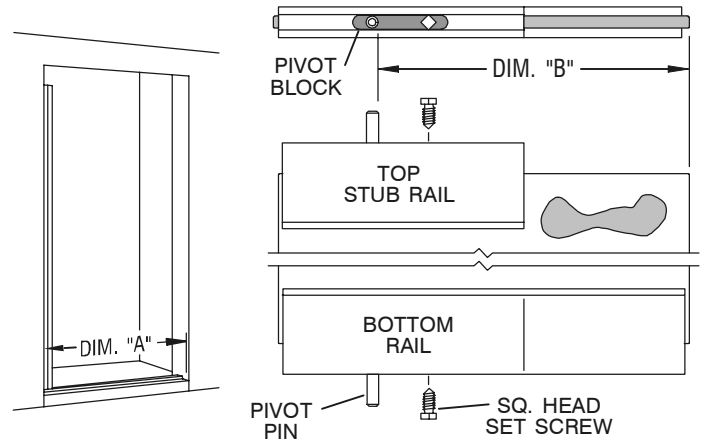

# 8

Insert a nylon pivot bushing [R] into the bottom pivot bracket [E]. Slip the second pivot bushing over the top pivot pin on the door panel [L]. Position the door by inserting the bottom pivot pin into the bottom pivot bracket. Hold the door panel vertical and slide the top pivot bracket into the pivot jamb [D] and over the top pivot pin and pivot bushing. Secure the top pivot bracket with a #6 x 3/8" truss head screw [F] and a #8-32 x 1/8" allen set screw [G].

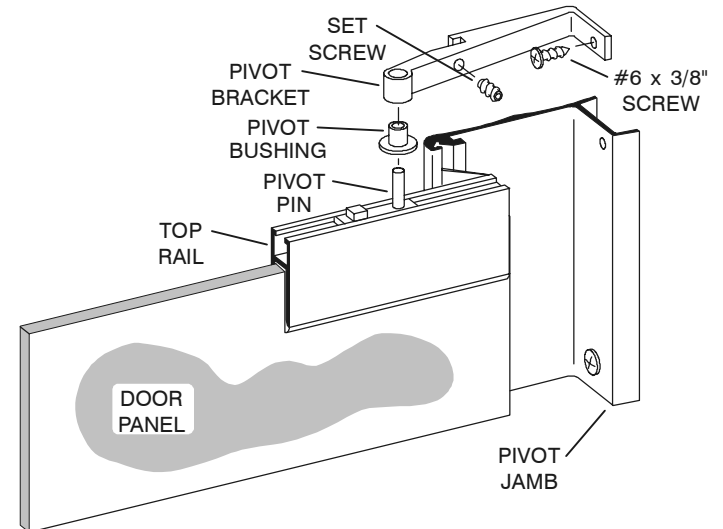

# 9

Set the strike jamb [S] 15/16" back from the front edge of the curb [A] and use the door edge as a guide to align it vertically. Hold the jamb in position and mark the hole locations.

Remove the jamb and drill the mounting holes as described in Step #5. Replace the strike jamb and attach to the wall with three #8 x 1 1/2" flat head screws [T].

Trim the flap on the clear vinyl strike jamb seal to clear the bottom door rail.

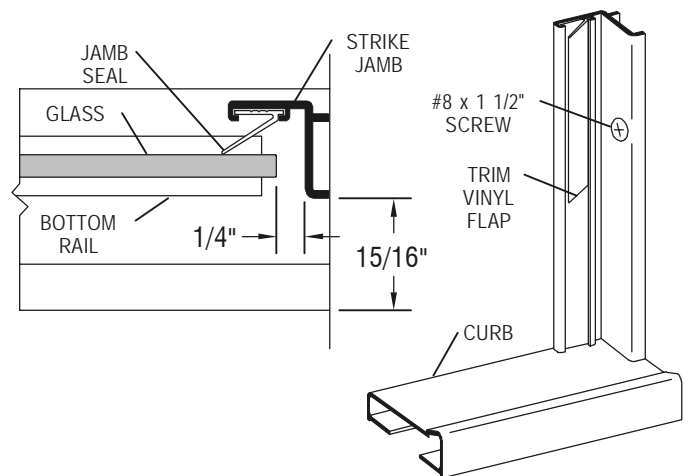

## 10

Slide the door handle [U] with magnet onto the strike edge of the door panel [L]. Close the door and slide the handle up or down until the two magnetic strips are aligned. Use a pencil or masking tape to mark the location of the handle on the door.

Slip the door handle vinyl [V] onto the door between the marks and carefully drive the door handle on the door panel. Spraying glass cleaner or water onto the vinyl and handle will make assembly easier.

Close the door and check the clearance with the strike jamb. If necessary, loosen the set screws [N] on the top & bottom pivot blocks [P] and adjust the door to align the strike magnets. When the door is properly aligned, tighten the set screws securely.

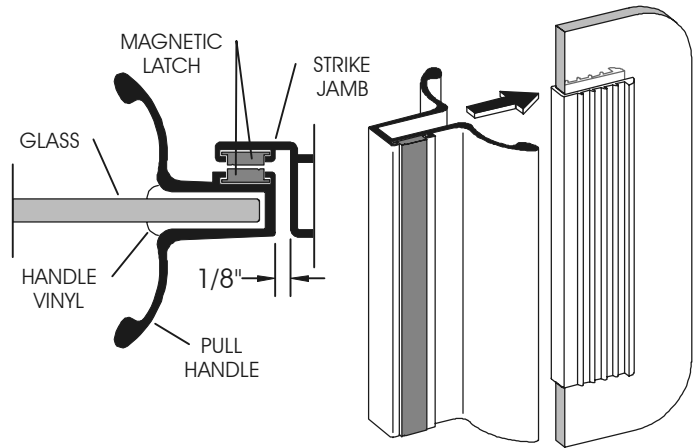

## 11

Cut the drip rail [W] to the length of the complete bottom rail minus  $11/16$ ". Clean the inside edge of the bottom door rail and the flat side of the drip rail thoroughly to ensure proper adhesion of the double stick tape [B]. Unroll the tape and carefully attach it to the back of the drip rail (do not peel the tape backing yet).

Insert the tapered drip vinyl [X] into the drip rail. Position the drip rail flush with the bottom and pivot side of the door panel [L], then raise the strike side until the bottom edge of the drip vinyl is parallel to the curb [A]. Mark the location of each end of the drip rail with a pencil.

**NOTE: Cleaners with alcohol content can dissolve the adhesive that attaches the drip rail. To prevent this possibility, place a small bead of clear sealant at the top of the drip rail where it is attached to the bottom rail.**

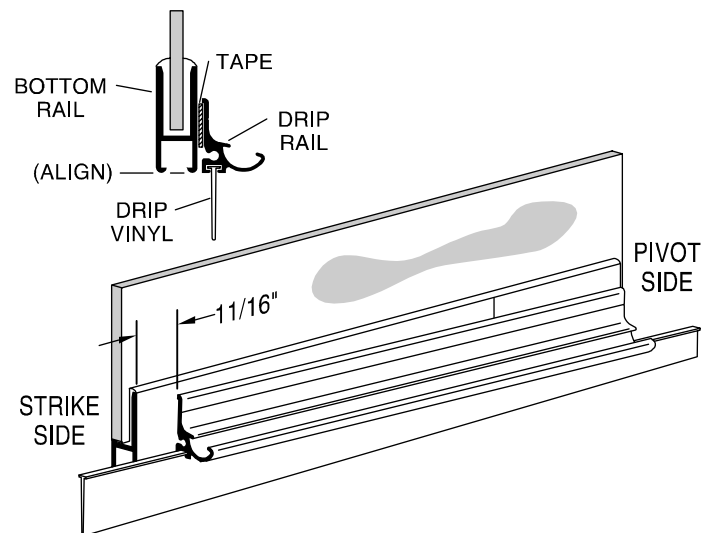

## 12

Adjust the drip vinyl [X] by sliding it left or right until it just touches the curb. Trim the vinyl (flush with the pivot end and notch  $1/2$ " longer than the drip rail as shown on the strike end). Secure it with one #6 x  $3/8$ " truss head screw [F] in the pivot end of the drip rail.

The drip plug [Y] is supplied with a left and right hand plug together. Break the right and left drip plug apart and insert the appropriate plug into the high (strike) side of the drip rail. Discard the unused drip plug. Peel off the tape backing and carefully press the drip rail to the door in the marked position.

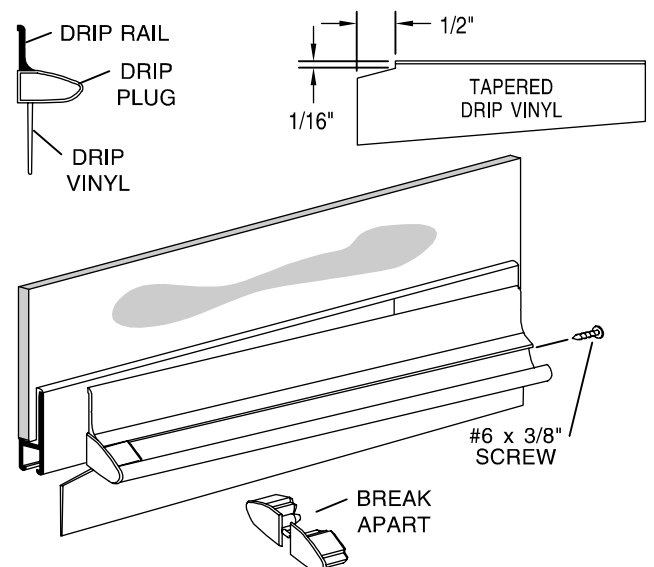

---

---

# 13

Press the four rail end caps [AA] into the ends of the top and bottom door rails.

**NOTE: Do not use a metal hammer to install the end caps.**

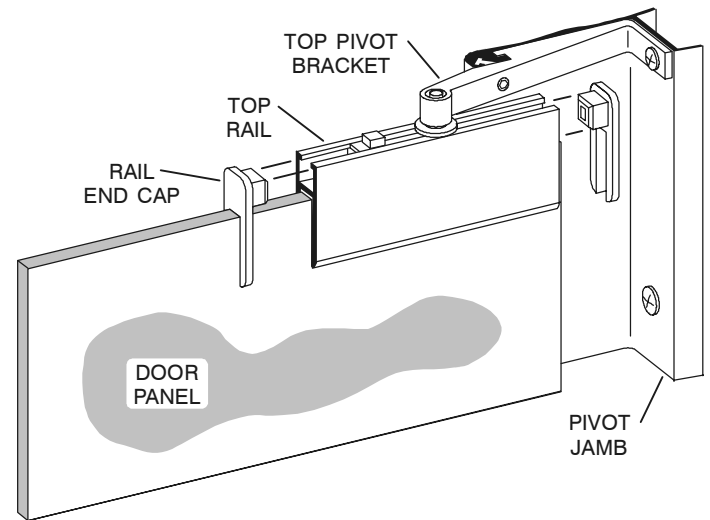

---

---

# 14

Neatly caulk the inside perimeter of the shower curb and the pivot and strike jambs.

**NOTE: The caulking should be allowed to cure for twenty-four hours before using your new shower enclosure.**

