

TECHNICAL SPECIFICATIONS – PIVOT & HINGE DOORS

738 - Pivot - 5/32" Glass

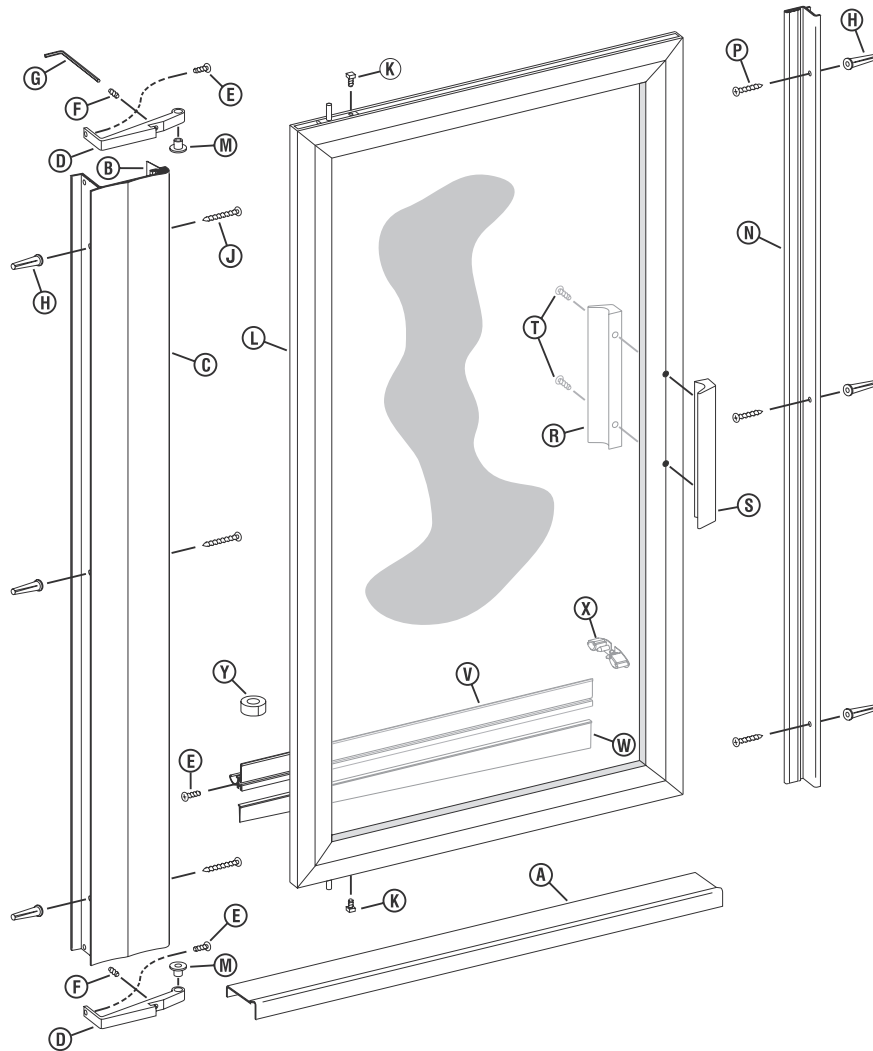

- | | | |
|--|--|--|
| A. 1 SC-915 Curb | H. 6 Plastic Wall Anchors | R. 1 Interior Door Handle |
| B. 1 Jamb Wiper Vinyl | J. 3 #8 x 2 Truss Head Screws | S. 1 Exterior Door Handle |
| C. 1 SC-621 Pivot Jamb | K. 2 #10 x 7/16 Sq. Head Set Screws | T. 2 #6 x 1 1/4 Round Head Screws |
| D. 2 Pivot Brackets | L. 1 Glazed Door Panel | V. 1 SC-589 Drip Rail |
| E. 3 #6 x 3/8 Truss Head Screws | M. 2 Nylon Pivot Bushings | W. 1 Tapered Drip Vinyl |
| F. 2 #8 x 1/8 Allen Set Screws | N. 1 SC-551 Strike Jamb (Magnetic) | X. 2 Drip Plugs |
| G. 1 Allen Wrench (5/64) | P. 3 # 8 x 1 1/2 Flat Head Screw | Y. 1 Roll of Double Stick Tape |

Calculations

Maximum allowable width of unit = 37 (@ 72 tall)
 Maximum allowable height of unit = 84 (@ 30 wide)

Glass Size

Width = Unit width - 3 5/8
 Height = Unit ht. - 3 1/2

Adjustment for Wall Conditions

± 1/4" on Strike Jamb
 ± 3/8" on Pivot Jamb

Metal Cuts

SC-551 strike jamb = Unit ht. - 1
 SC-549 strike rail = Unit ht. - 1 1/2
 SC-589 drip rail = SC-899 bottom rail - 11/16
 SC-621 pivot jamb = Unit ht. - 7/16
 SC-899 top & bottom rails = Unit width - 1 3/4
 SC-900 pivot rail = Unit ht. - 1 1/2
 SC-915 curb (optional) = Unit width