

## New Hinge Sleeve Installation

Measure the length of the jamb from one "ball" notch to the other. Cut the V-347 vinyl to that length minus  $4\frac{1}{16}$ ". Slide the vinyl over the ball and center the open ends on the jamb.

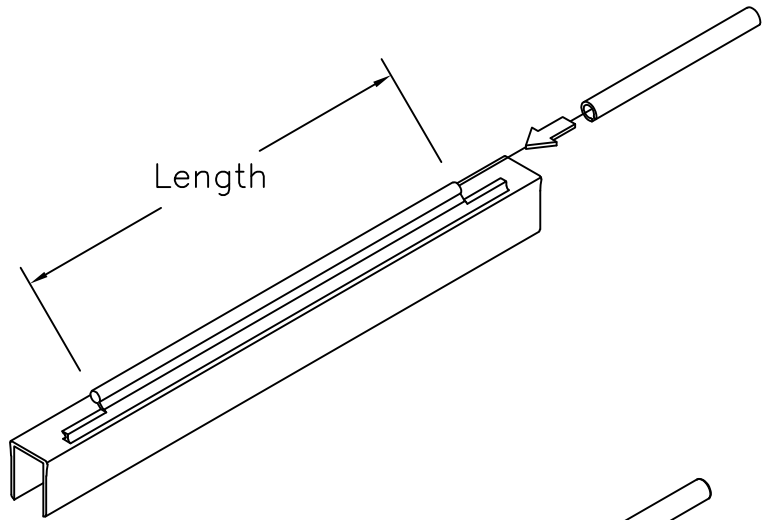

Slide a hinge sleeve over each end of the hinge jamb.

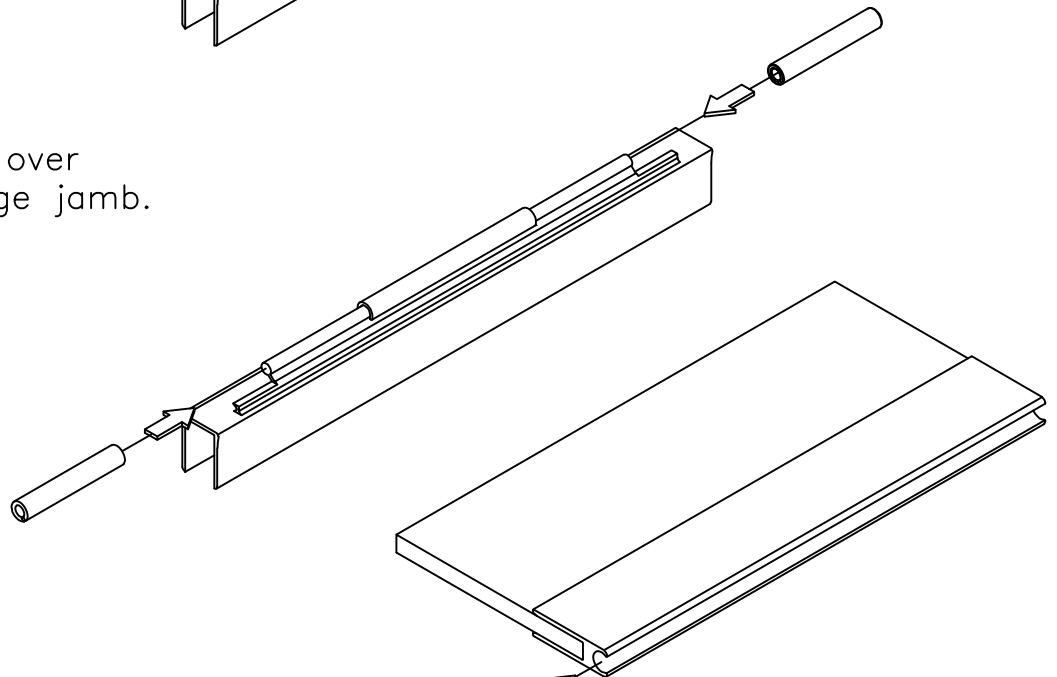

Slide hinge jamb assembly into the hinge rail after glazing.

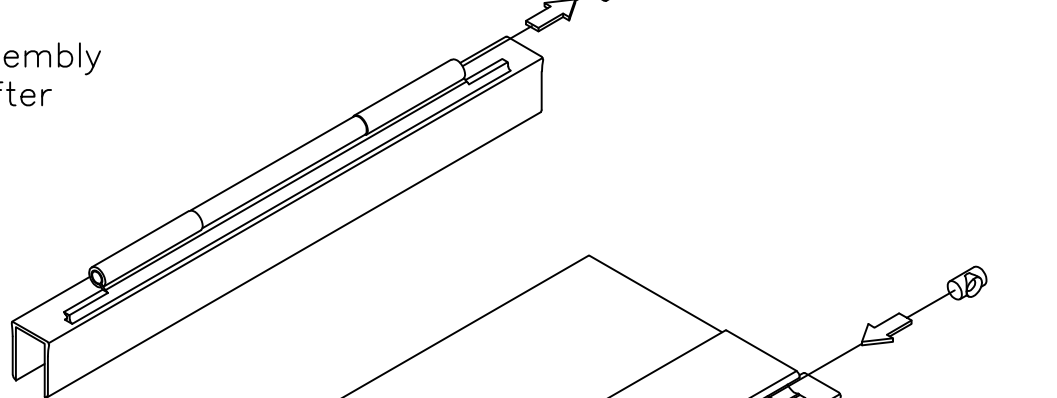

Insert a pivot bushing into one end of the hinge rail and attach to the rail with the #8-32 x  $1/2$  screw. Repeat for the other end.

